

Stainless Steel Core Filling Snack Food Processing Line Self Cleaning, 220/380/415V

Specifications :

Price	Contact Us
Brand Name	Loyal
Place of Origin	Shandong, China
Min.Order Quantity	1 set
Payment Terms	L/C,D/P,T/T,Western Union,MoneyGram
Supply Ability	20days / Snack Food Production Line
Delivery Detail	20days--35days
Packaging Details	Wooden case or wooden pellets depended on clients' requirement
Certification:	CE,ISO9001,SGS?BV

Detail Introduction :

DESCRIPTION OF HIGH AUTOMATIC CORE FILLING SNACK FOOD PROCESSING LINE SELF CLEANING, 220/380/415V

? WHY CHOOSE HIGH AUTOMATIC CORE FILLING SNACK FOOD PROCESSING LINE SELF CLEANING, 220/380/415V?

? HOW TO MAKE CORE-FILLING SNACK?

What equipments need for making Core-filling snack?

? FEATURES OF HIGH AUTOMATIC CORE FILLING SNACK FOOD PROCESSING LINE SELF CLEANING, 220/380/415V

? TECHNICAL PARAMETERS FOR HIGH AUTOMATIC CORE FILLING SNACK FOOD PROCESSING LINE SELF CLEANING, 220/380/415V

? PHOTOS OF CORE FILLING CORN SNACK FOOD SAMPLES

DESCRIPTION OF HIGH AUTOMATIC CORE FILLING SNACK FOOD PROCESSING LINE SELF CLEANING, 220/380/415V

Snack food is a kind of crisp food with smooth taste and strong flavor. Sandwich puffed food is processed by a special structure of extruder. Compared with the traditional method, the output, quality, and raw material adaptability have been improved by one step, making it possible to strengthen vitamins and minerals and other trace elements. Core-filling snack production line has the characteristics of many optional models, flexible equipment configuration, wide range of raw materials, many product types, and simple operation. By changing different molds and changing the production process, various puffed foods popular on the market can be produced by Core-filling snack production line, which is suitable for various food manufacturers.



Description of high Automatic Core Filling Snack Food Processing Line

High Automatic Core Filling Snack Food Processing Line	
1	advanced double screw extruding technique
2	use corn powder, rice powder, and other grain powder as main materials, and other nutritional ingredients can be added.
3	can produce many kinds of extrusion puffed snacks with or without core fillings.
4	can use chocolate jam, peanut butter, cheese cream, etc as core fillings.
5	such double screw extruder can also produce other products, like breakfast cereal, nutritional rice and powder, bread crumb, crispy rice, etc.
6	convenient operation and maintenance, low power consumption, high output are its characteristics.

?WHY CHOOSE HIGH AUTOMATIC CORE FILLING SNACK FOOD PROCESSING LINE SELF CLEANING, 220/380/415V?



High Automatic Core Filling Snack Food Extruder

Description of high Automatic Core Filling Snack Food Processing Line	
1	The body plate and parts contacting food are all stainless steel.
2	All the brands of motors, inverters, and electrical elements can be adjusted as clients requirements.
3	With adopting the latest Italy design concept to do proper improvement for the structure of screw and barrel to make sure that screw won't grind inside the barrel. This will not only extend their use life, and also avoid the grind iron scrap mixing into the material.
4	Unique design of the diversion-cone enables the uniform discharging, and pressure equalizing for the discharge point of the die.
5	The rational barrel and screw cooling structure and effective heating unit assure the accuracy of temperature control.

?HOW TO MAKE CORE-FILLING SNACK?

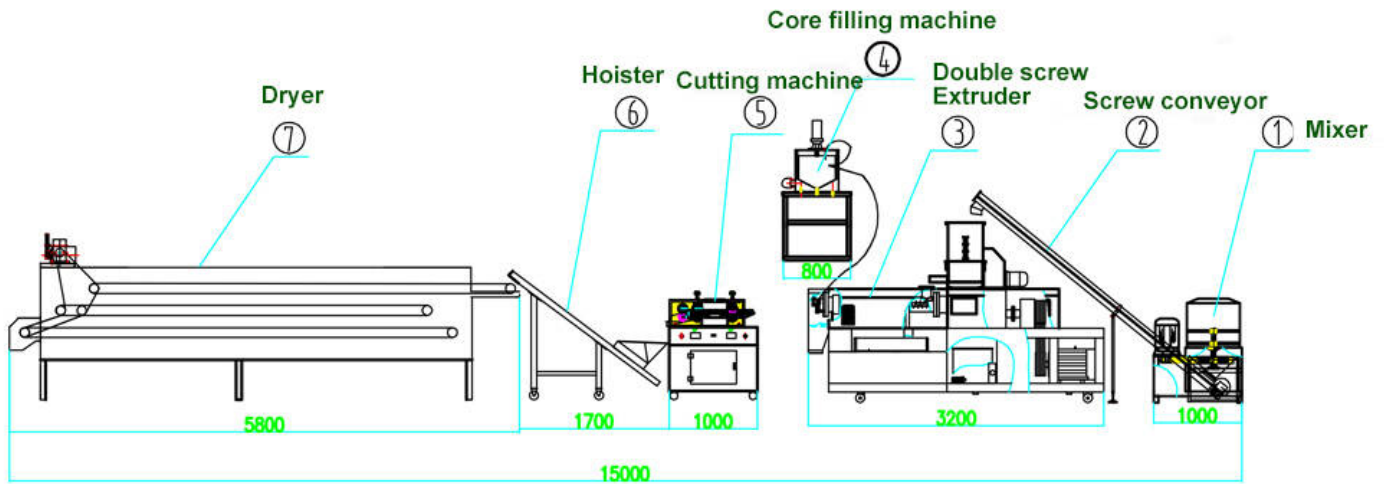

Core Filling Snack Food Processing Line Flow Chart

Mixing system---Extrusion system----Cutting system---Drying system---Flavoring System
Whats equipments need for making Core-filling snack?



Core Filling Snack Food Processing Line

Fuction Of Each Core Filling Snack Food Processing Line

Mixer	Mix the ingredients (corn flour, rice flour, flour, etc.) well and then add a certain amount of water to mix well.
Screw Hoister	Using the motor as the power spiral conveying, the mixed raw materials are conveyed to the feeding hopper of the extruder, ensuring convenient and quick feeding.
Double Screw Extruder	According to the production line output choose different models of puffing extruder, output varies, raw materials can be corn flour, rice flour, flour, grain flour and other raw materials.
Pvc Hoister(Air Conveyor)	Transporting puffed food to the dryer
Dryer	The temperature of the oven is between 0-200?, which can be adjusted by the control cabinet. The inside is a stainless steel double-layer mesh. The baking time can be adjusted according to the speed. Through the baking, the puffed food can penetrate to a certain extent, increase the taste, and reduce material moisture at the same time increases the shelf life.
Cutting Machine	The multifunctional plastic cutting machine has multiple functions of traction, transportation, shaping and cutting. It is generally used to cut small foods such as cylindrical, flat and long tubes, such as sandwiched rice crackers, rice old heads and other semi-puffed or non-puffed foods, or more Long sandwich food.
Flavoring Machinery	According to the output and product properties, different types of seasoning systems are configured, and there are also equipment for oil spraying, sugar spraying, and coating etc.,
(Adoptional Machinery: Grinding Machinery,Packing Machinery)	

?FEATURES OF HIGH AUTOMATIC CORE FILLING SNACK FOOD PROCESSING LINE SELF CLEANING, 220/380/415V

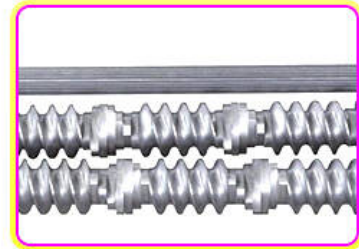
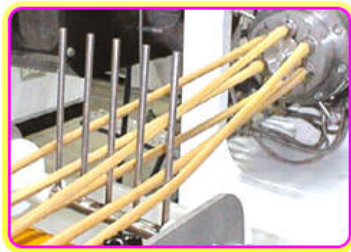

Core Filling Snack Food Processing Line Flow Chart Equipment Materials

Core Filling Snack Food Processing Line Flow Chart Equipment Materials	
1	The chocolate pillow snack making machine has the advantage of rational design, high automatic degree and accuracy control.
2	The main body material is stainless steel, which is good and easy to be cleaned.
3	The screws material is 38CrMnAl, which is wear-resisting.
4	Our project is turn-key. We will send our engineer to your factory, install and debug the equipments, and train your operators.
5	The temperature and rotating speed can be controlled and adjusted.

?TECHNICAL PARAMETERS FOR HIGH AUTOMATIC CORE FILLING SNACK FOOD PROCESSING LINE SELF CLEANING, 220/380/415V



Core Filling Snack Food Processing Line Flow Chart Equipment Materials

Parameters Of Core Filling Snack Food Processing Line		
Model	Output	Size (L*W*H)
LY65	120-150kg/h	21000x1200x2200mm
LY70L	200-250kg/h	23000x1500x2200mm
LY85	300-500kg/h	28000x3500x4300mm
LY75	400-500kg/h	24000*2000*2800
LY95	800-1200kg/h	31000*3500*4300

?PHOTOS OF CORE FILLING CORN SNACK FOOD SAMPLES

The extrusion snacks food machinery can produce different shape snacks by changing the die, following are the snacks photos for your reference:



PHOTOS OF CORE FILLING CORN SNACK FOOD SAMPLES



PHOTOS OF CORE FILLING CORN SNACK FOOD SAMPLES
WHY CHOOSE US?
COMPANY PROFILE OF LOYAL INDUSTRIAL

○ **FACTORY PHOTO** ○



CORE FILLING CORN SNACK FOOD FACTORY

Shandong Loyal Industrial Co., Ltd. is actually specialist manufacturer of meals equipment, snack foods machines. Experienced developers is helping us whose project is to research brand-new machines, design for clients, compensation equipment for customers. 1 day's solution as well as 15 after sales solution staffs aid our clients to handle all the errors of our devices immediately. We are professional manufacturer of food machine. We mainly deal with the manufacture, research and development of the snacks food machinery. According to clients' different demands, we could offer the whole complete processing line for all kinds of expanded snacks, 2D and 3D pellet, potato chips, corn flakes, nutrition powder, pet food and so on. And our technical assistance will help clients produce high quality products all the time.

OUR SERVICE

CLIENTS PHOTO



CUSTOMER VISIT CORE FILLING CORN SNACK FOOD FACTORY

Service For Core Filling Corn Snack Machinery

Service for Pre-sale

1. Provide technical parameter
2. Factory layout and size suggestion
3. Provide general formulation
4. Custom-Design service
5. Professional Advice about Market, machines, materials, packing
6. Suggesting professional ship agent or helping book ship as customer request.
7. 24 hours online service.

Service for After-sale

1. Allocation chart as the buyer's request will be supplied.
2. Operation manual will be supplied after shipment.
3. One year warranty, life time maintenance with cost price.
4. Free easy broken spare parts will be sent with container .
5. First installation can be done by engineer.
6. Training workers in customer's factory.

OUR HONOR

OUR CERTIFICATE



CE ISO9001 certificates SGS 15 patents 2000 square factory

Certificate for core filling machine

Shandong Loyal Industrial Co., Ltd., as a professional manufacturer of food processing machines, has a strong and experienced sales and service team to ensure high-quality products. We have obtained CE, ISO, SGS, and our machines have been exported to many countries and regions. We provide customers with complete solutions. You are welcome to inquire.

FAQ

Q: Are you trading company or manufacturer ?

A: We are factory.

Q: How long is your delivery time?

A: Generally it is 5-10 days if the goods are in stock. or it is 20-30 days if the goods are not in stock, it is according to quantity.

Q: Do you provide samples ? is it free or extra ?

A: Yes, we could offer the sample for free charge but do not pay the cost of freight.

Q: What is your terms of payment ?

30% is paid by T/T as the down payment, 70% is paid by T/T or L/C before shipment

Q:Guarantee?

Within 12 months

Q:Contact Information?

Any question please contact us! Welcome to Shandong Loyal.

Customer Cases For Core Filling Snack Food Processing Machine For Factory In 2021

Shandong Loyal Industrial relies on complete product specifications, excellent product quality and professional services. It has been widely recognized by customers, obtained a good brand image, has mature and stable sales channels, and accumulated a large number of high-quality customers. At present, the company's products are in short supply and are exported to Asia, Europe, North America, Africa, South America and Oceania, with customers in more than 50 countries and regions around the world. If you are interested in the Core filling snack food processing machine, please contact LOYAL immediately, we will provide you with high-quality formulations of Core filling snack food processing machine, professional technical process guidance, and a full range of professional market analysis.

Customer Cases For Core Filling Snack Food Processing Machine For Factory In 2021	
1	1t/h Ce Certificated Rice Pie Snack Food Machine Jam Center Processing Line Core Filling Machine For Factory
2	1t/h New Design Making Puff Rice Puffed Automatic Corn Sticks Food Machine Core Filling Snack Extruder Line For Sale In Puerto Rico Customer Factory
3	1t/h Food Core Filling Snack Processing Line Snack Processing Machine Puffed Food Making Machine Snack Processing Line Manufacturing Plant Installed In Customer Factory For Sale In Bolivia Customer
4	Senegal 1t/h Food Extruder - For Core Filling Snacks Processing Line
5	1t/h Energy Saving Large Core Food Filling Snack Processing Line Snacks Making Extruder Auto Core Machine Puff Filling Snack Processing Line Making Extruder For Sale In Côte d'Ivoire
6	China 300t/Year Snack Food Making Processing Line Grain Processing Machinery Corn Puff Snack Extruder

Customer Second Order Of High Quality Core Filling Puff Extrusion Snack Food Machine Processing Line For Sale At 2021	
1	1t/h Cheese Extruded Crispy Core Filling Pop Corn Puff Snack Processing Line In Uzbekistan
2	1000kg/h Core Filling Snack Food Processing Machine For Sale In Senegal
3	Mozambique 1t/h Fully Automatic Core Filling Snack Food Processing Machine
4	Bangladesh 2t/h Extruded Crispy Core Filling Pop Corn Puff Snack Processing Line Pillow Filled Snack Processing Line
5	1t/h Thai Industrial High Quality Core-Filled Snacks Processing Line Ice Cream Core Filling Snack Food Processing Line
6	Uzbekistan 1t/H Double Screw Extruder Core Filled Rice Snack Food Processing Line
7	Usa 1t/h Double Screw Extruder Core Filled Rice Snack Food Processing Line
8	800kg/h Indian High Quality Core-Filled Snacks Processing Line Ice Cream Core Filling Snack Food Processing Line
9	Dealed Customer Have Technology Of Double Screw Extruder Core Filled Rice Snack Food Processing Line

2021Customer Case Of Pay By T/T For Kurkure Snack Food Machine	
1	1t/h Industrial Double Screw Extruder Core Filled Rice Snack Food Processing Line

2	1000kg/h Double Screw Extruder Core Filled Rice Snack Food Processing Line For Sale In Anguilla
3	Bahrain 1t/h Fully Automatic Kurkure Making Machine
4	Bangladesh 2t/h Fdouble Screw Extruder Core Filled Rice Snack Food Processing Line
5	1t/h Bouvet Islands High Quality Core-Filled Snacks Processing Line Ice Cream Core Filling Snack Foo
6	Central African Republic 1t/H Double Screw Extruder Core Filled Rice Snack Food Processing Line
7	Colombia 1t/h Kurkure Snack Processing Line
8	800kg/h Double Screw Extruder Core Filled Rice Snack Food Processing Line
9	Gambia Customer Have Technology Of High Quality Core-Filled Snacks Processing Line Ice Cream Co Machine At 2021