

# 120kg-1200kg/h Corn Puff Making Machine/ Production Line For Rice, Maize Type

## Specifications :

Price	Contact Us
Brand Name	Loyal
Place of Origin	Shandong, China
Min.Order Quantity	1 set
Payment Terms	L/C,D/P,T/T,Western Union,MoneyGram
Supply Ability	20days / Snack Food Production Line
Delivery Detail	20days--35days
Packaging Details	Wooden case or wooden pellets depended on clients' requirement

## Detail Introduction :

DESCRIPTION OF 120KG-1200KG/H CORN PUFF MAKING MACHINE/ PRODUCTION LINE FOR RICE, MAIZE TYPE

TECHNICAL PARAMETERS FOR 120KG-1200KG/H CORN PUFF MAKING MACHINE/ PRODUCTION LINE FOR RICE

?SAMPLE PICTURES OF 120KG-1200KG/H CORN PUFF MAKING MACHINE/ PRODUCTION LINE FOR RICE

FLOW CHART OF 120KG-1200KG/H CORN PUFF MAKING MACHINE/ PRODUCTION LINE FOR RICE,

TECHNICAL PARAMETERS FOR 120KG-1200KG/H CORN PUFF MAKING MACHINE/ PRODUCTION LINE FOR RICE

?BRIEF INTRODUCTION OF MAIN MACHINES

?FEATURES OF DOUBLE SCREW EXTRUDER

## DESCRIPTION OF 120KG-1200KG/H CORN PUFF MAKING MACHINE/ PRODUCTION LINE FOR RICE, MAIZE TYPE

Corn puffs snack production line can use corn flour, rice flour, wheat flour and other grain powder as raw materials, to produce different shape puff snacks by changing the extruder mould, such as chips, ball, ring, stick, flake, flower shapes etc. Cheese ball snack making machine adopt advanced extrusion technology with high efficiency instead of traditional steam boiling process. It has features of continuous working, stable performance and reasonable design.



## 120KG-1200KG/H CORN PUFF MAKING MACHINE/ PRODUCTION LINE FOR RICE, MAIZE TYPE

1. Main extruder is equipped with high and low pressure screw, which expands the scope of raw material, reduces the cost and modify the product quality.
2. Main product: Corn puffs snack production line can be used to produce many kinds of shapes as like round balls, rings, flower, heart shape, stars, animals, alphabetic ABC or 123 and so on.
3. Rice puffing snack machine performance and products quality reach to the most advanced level in the world.
4. High efficiency, low consumption, easy to operate and maintain.
5. Materials: adopts rice powder, corn powder, millet powder, wheat powder, oats, buckwheat, bean, starch, etc.

## **TECHNICAL PARAMETERS FOR 120KG-1200KG/H CORN PUFF MAKING MACHINE/ PRODUCTION LINE FOR RICE**

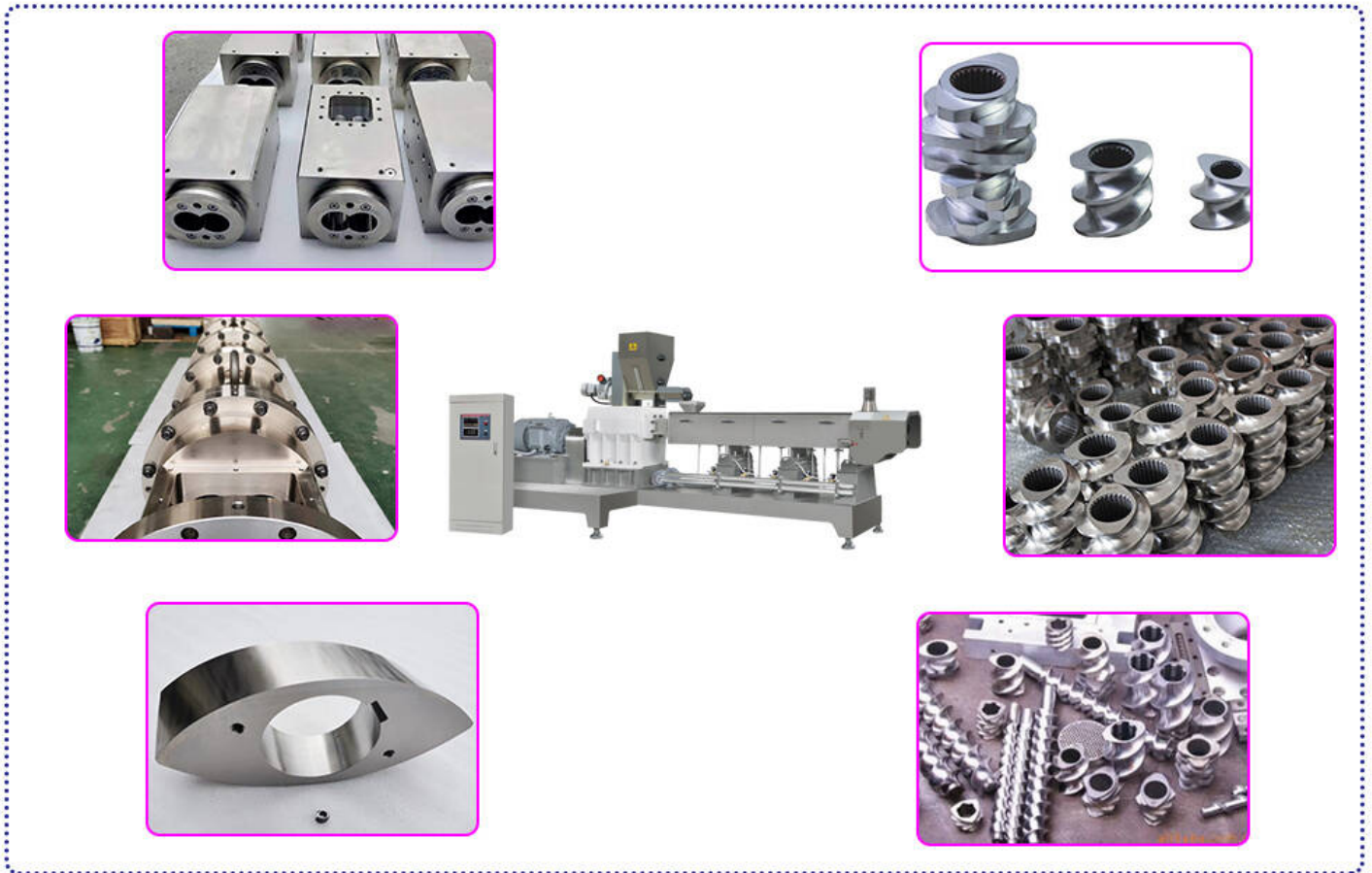

## TECHNICAL PARAMETERS FOR 120KG-1200KG/H CORN PUFF MAKING MACHINE/ PRODUCTION LINE

TECHNICAL PARAMETERS FOR 120KG-1200KG/H CORN PUFF MAKING MACHINE/ PRODUCTION LINE	
<b>Product Name</b>	Full automatic corn puffs snack production line/cheese ball snack making machine/rice puffing snack machine
<b>energy</b>	You can choose electricity or gas or diesel or steam as some machine energy
<b>Standard</b>	The motor most of with Siemens made in china or china top brand inverter, also with good brand electricity parts
<b>Function</b>	Multiple
<b>Type</b>	Twin screw extruder machine
<b>Application</b>	Corn puffs snack production line
<b>Capacity</b>	100 kg/h, 150 kg/h, 250 kg/h, 500 kg/h, 1000 kg/h
<b>Voltage</b>	Three phases: 380V/50Hz, Single phase: 220V/50Hz, We can make it according to customers' Local voltage according to different countries
<b>Machines Materials</b>	All the corn puffs snack production line are made by stainless steel, this line is with reasonable design and with high automation; the screws are made by alloy steel, with building block system structure and self-cleaning function

## ?SAMPLE PICTURES OF 120KG-1200KG/H CORN PUFF MAKING MACHINE/ PRODUCTION LINE FOR RICE

Crustaceans, crispy corners, shell crisps, brown rice rolls, small screws, salads, pizza rolls, cat's ear crisps, escargots, oat rolls, etc.



SAMPLE PICTURES OF 120KG-1200KG/H CORN PUFF MAKING MACHINE/ PRODUCTION LINE FOR RICE



SAMPLE PICTURES OF 120KG-1200KG/H CORN PUFF MAKING MACHINE/ PRODUCTION LINE FOR RICE

## FLOW CHART OF 120KG-1200KG/H CORN PUFF MAKING MACHINE/ PRODUCTION LINE FOR RICE,

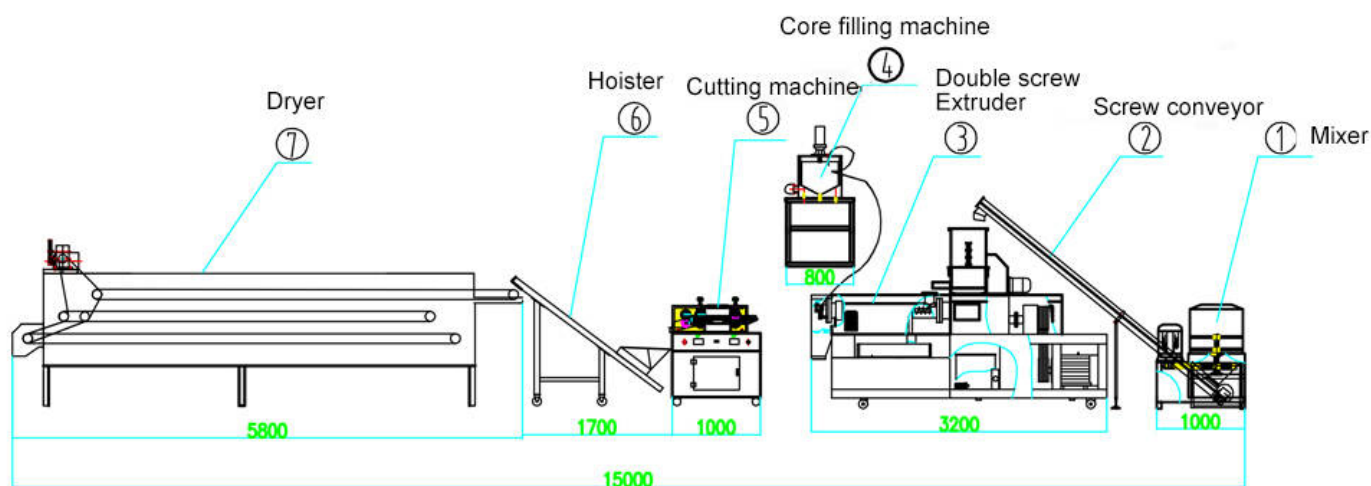

FLOW CHART OF 120KG-1200KG/H CORN PUFF MAKING MACHINE/ PRODUCTION LINE FOR RICE,

Mixing system---Extrusion system----Cutting system---Drying system---Flavoring System

# TECHNICAL PARAMETERS FOR 120KG-1200KG/H CORN PUFF MAKING MACHINE/ PRODUCTION LINE FOR RICE



## TECHNICAL PARAMETERS FOR 120KG-1200KG/H CORN PUFF MAKING MACHINE/ PRODUCTION LINE

TECHNICAL PARAMETERS FOR 120KG-1200KG/H CORN PUFF MAKING MACHINE/ PRODUCTION LINE		
Model	Output	Size (L*W*H)
LY65	120-150kg/h	21000x1200x2200mm
LY70L	200-250kg/h	23000x1500x2200mm
LY85	300-500kg/h	28000x3500x4300mm
LY75	400-500kg/h	24000*2000*2800
LY95	800-1200kg/h	31000*3500*4300

## ?BRIEF INTRODUCTION OF MAIN MACHINES



### 120kg-1200kg/h Corn Puff Making Machine/ Production Line For Rice, Maize Type

120kg-1200kg/h Corn Puff Making Machine/ Production Line For Rice, Maize Type	
Mixer	Mix the ingredients (corn flour, rice flour, flour, etc.) well and then add a certain amount of water to mix well.
Screw Hoister	Using the motor as the power spiral conveying, the mixed raw materials are conveyed to the feeding hopper of the extruder, ensuring convenient and quick feeding.
Double Screw Extruder	According to the production line output choose different models of puffing extruder, output varies, raw materials can be corn flour, rice flour, flour, grain flour and other raw materials.
PVC hoister(Air Conveyor)	Transporting puffed food to the dryer
Dryer	The temperature of the oven is between 0-200?, which can be adjusted by the control cabinet. The inside is a stainless steel double-layer mesh. The baking time can be adjusted according to the speed. Through the baking, the puffed food can penetrate to a certain extent, increase the taste, and reduce material moisture at the same time increases the shelf life.
Cutting machine	The multifunctional plastic cutting machine has multiple functions of traction, transportation, shaping and cutting. It is generally used to cut small foods such as cylindrical, flat and long tubes, such as sandwiched rice crackers, rice old heads and other semi-puffed or non-puffed foods, or more Long sandwich food.

Flavoring Machinery	According to the output and product properties, different types of seasoning systems are configured, and there are also equipment for oil spraying, sugar spraying, and coating etc.,
(Adoptional Machinery: Grinding Machinery,Packing Machinery)	

## ?FEATURES OF DOUBLE SCREW EXTRUDER



### FEATURES OF DOUBLE SCREW EXTRUDER

The machine is composed of a feeding system, an extrusion system, a rotary cutting system, a heating system, a transmission system, and a control system. It adopts advanced screw extrusion technology and uses high temperature and high pressure to mature and expand the material into one-time completion. The host adopts frequency conversion speed regulation to ensure the stability of the production process. Product colors, varieties, beautiful appearance, natural and lifelike, delicate texture, wide use of raw materials.

FEATURES OF DOUBLE SCREW EXTRUDER	
1	Series of double-screw extruder mainly consist of feeding system, extruding system, cutting system, heating system, lubricating system and controlling system.
2	Automatic lubricating and forced cooling make sure that extruder performs safely and extends using life.



3	Feeding system, extruding system and cutting system all adopt frequency conversion timing to gain powerful drive, stable perform, and electricity saving.
4	Screw are made of alloy and processed by special technique to possess high intensity, abrasion resistant and longer using life.
5	There are six sections of heaters, controlled by PID models; there are thermocouple sensors
6	There are frequency converters for main motor, paper cutter and paper feeder; various speeds are available
7	The screw is made of 38CrMoAL; after nitriding; the hardness is HRC55-60
8	There is an additional cooling system in the lubricating oil tank to ensure the cooling oil at low temperatures

### ?WHY CHOOSE US?

### COMPANY PROFILE OF LOYAL INDUSTRIAL

## ○ FACTORY PHOTO ○



### Snacks machinery factory

Loyal brand was famous well-known at global and domestic market, and it is sold to more than 50 countries and regions, with ISO system, SGS certificate, 10 CE certificates, and 25 patents on Technology Patent, since then, we keep forward on the quality control, new technology developing and the better customer service.

Shandong Loyal Industrial Co., Ltd. is actually specialist manufacturer of meals equipment, snack foods machines. Experienced developers is helping us whose project is to research brand-new machines, design for clients, compensation equipment for customers. 1 day's solution as well as 15 after sales solution staffs aid our clients to handle all the errors of our devices immediately.

We are professional manufacturer of food machine. We mainly deal with the manufacture, research and development of the snacks food machinery. According to clients' different demands, we could offer the whole complete processing line for all kinds of expanded snacks, 2D and 3D pellet, potato chips, corn flakes, nutrition powder, pet food and so on. And our technical assistance will help clients produce high quality products all the time.

**OUR SERVICE**

○ CLIENTS PHOTO ○



**Customer visit puffy snacks machinery factory**

Service for puffy snacks machinery factory	
Service for Pre-sale	Service for After-sale
<ol style="list-style-type: none"> <li>1. Provide technical parameter</li> <li>2. Factory layout and size suggestion</li> <li>3. Provide general formulation</li> <li>4. Custom-Design service</li> <li>5. Professional Advice about Market, machines, materials, packing</li> <li>6. Suggesting professional ship agent or helping book ship as customer request.</li> <li>7. 24 hours online service.</li> </ol>	<ol style="list-style-type: none"> <li>1. Allocation chart as the buyer's request will be supplied.</li> <li>2. Operation manual will be supplied after shipment.</li> <li>3. One year warranty, life time maintenance with cost price.</li> <li>4. Free easy broken spare parts will be sent with container .</li> <li>5. First installation can be done by engineer.</li> <li>6. Training workers in customer's factory.</li> </ol>

**?OUR HONOR**

## OUR CERTIFICATE



CE ISO9001 certificates SGS 15 patents 2000 square factory

certified for puffy snacks factory

### Customer Cases For Core Filling Snack Food Processing Machine For Factory In 2021

Shandong Loyal Industrial relies on complete product specifications, excellent product quality and professional services. It has been widely recognized by customers, obtained a good brand image, has mature and stable sales channels, and accumulated a large number of high-quality customers. At present, the company's products are in short supply and are exported to Asia, Europe, North America, Africa, South America and Oceania, with customers in more than 50 countries and regions around the world. If you are interested in the Core filling snack food processing machine, please contact LOYAL immediately, we will provide you with high-quality formulations of Core filling snack

food processing machine, professional technical process guidance, and a full range of professional market analysis.

Customer Cases For Core Filling Snack Food Processing Machine For Factory In 2021	
1	1t/h Ce Certificated Rice Pie Snack Food Machine Jam Center Processing Line Core Filling Machine W Factory
2	1t/h New Design Making Puff Rice Puffed Automatic Corn Sticks Food Machine Core Filling Snack Ext Line For Sale In Puerto Rico Customer Factory
3	1t/h Food Core Filling Snack Processing Line Snack Processing Machine Puffed Food Making Machine Snack Processing Line Manufacturing Plant Installed In Customer Factory For Sale In Bolivia Customer
4	Senegal 1t/h Food Extruder - For Core Filling Snacks Processing Line
5	1t/h Energy Saving Large Core Food Filling Snack Processing Line Snacks Making Extruder Auto Core Machine Puff Filling Snack Processing Line Making Extruder For Sale In Côte d'Ivoire
6	China 300t/Year Snack Food Making Processing Line Grain Processing Machinery Corn Puff Snack Ext

Customer Second Order Of High Quality Core Filling Puff Extrusion Snack Food Machine Processing Line For Sale At 2021	
1	1t/h Cheese Extruded Crispy Core Filling Pop Corn Puff Snack Processing Line In Uzbekistan
2	1000kg/h Core Filling Snack Food Processing Machine For Sale In Senegal
3	Mozambique 1t/h Fully Automatic Core Filling Snack Food Processing Machine
4	Bangladesh 2t/h Extruded Crispy Core Filling Pop Corn Puff Snack Processing Line Pillow Filled Snack
5	1t/h Thai Industrial High Quality Core-Filled Snacks Processing Line Ice Cream Core Filling Snack Foo
6	Uzbekistan 1t/H Double Screw Extruder Core Filled Rice Snack Food Processing Line
7	Usa 1t/h Double Screw Extruder Core Filled Rice Snack Food Processing Line
8	800kg/h Indian High Quality Core-Filled Snacks Processing Line Ice Cream Core Filling Snack Food Pa
9	Dealed Customer Have Technology Of Double Screw Extruder Core Filled Rice Snack Food Processing

2021 Customer Case Of Pay By T/T For Kurkure Snack Food Machine	
1	1t/h Industrial Double Screw Extruder Core Filled Rice Snack Food Processing Line
2	1000kg/h Double Screw Extruder Core Filled Rice Snack Food Processing Line For Sale In Anguilla
3	Bahrain 1t/h Fully Automatic Kurkure Making Machine
4	Bangladesh 2t/h Fdouble Screw Extruder Core Filled Rice Snack Food Processing Line
5	1t/h Bouvet Islands High Quality Core-Filled Snacks Processing Line Ice Cream Core Filling Snack Foo
6	Central African Republic 1t/H Double Screw Extruder Core Filled Rice Snack Food Processing Line
7	Colombia 1t/h Kurkure Snack Processing Line
8	800kg/h Double Screw Extruder Core Filled Rice Snack Food Processing Line
9	Gambia Customer Have Technology Of High Quality Core-Filled Snacks Processing Line Ice Cream Co Machine At 2021